

Microcontroller

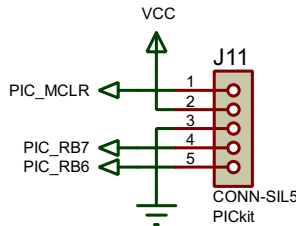

LCD

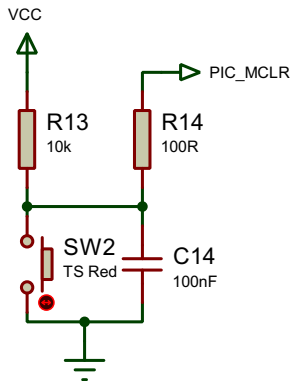
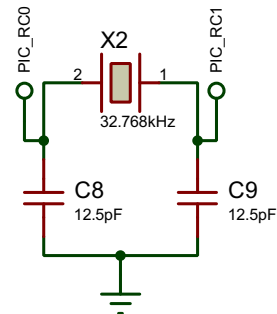
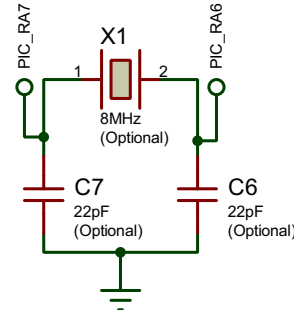
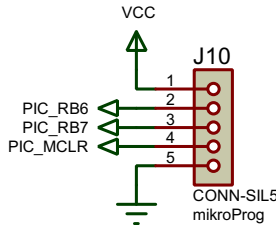
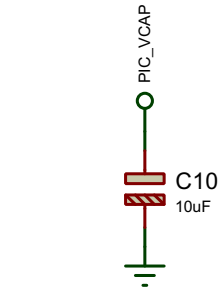
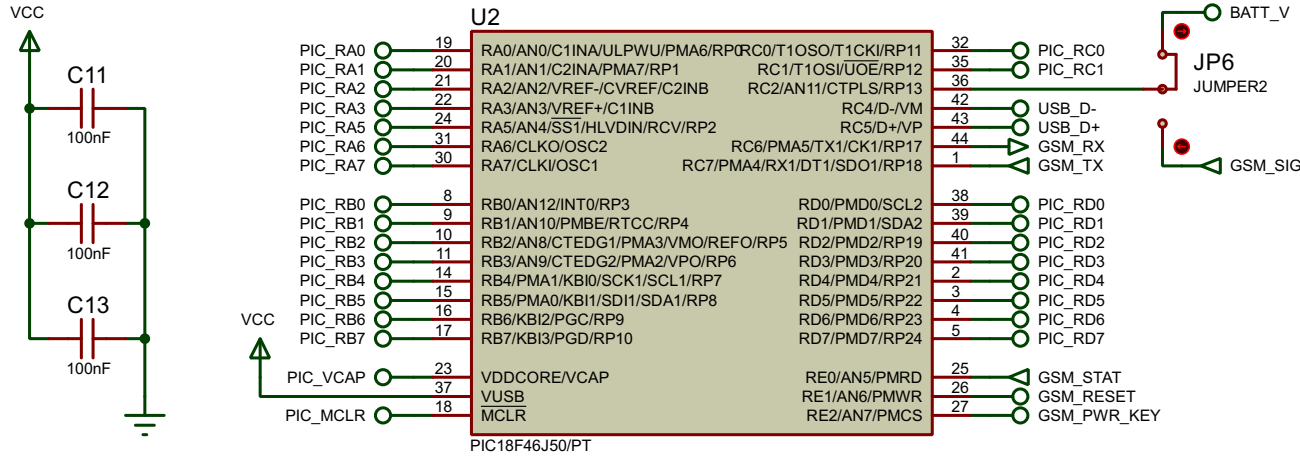
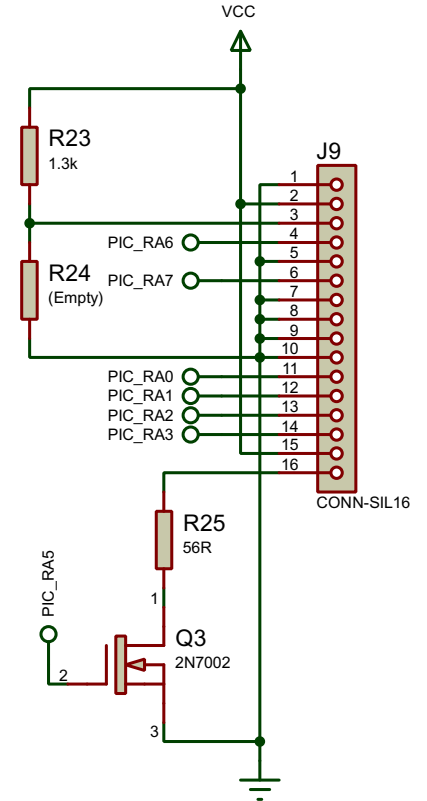

Connectors

SimPLC V2.0
 www.dizzy.co.za
 Designed in Proteus
 www.labcenter.co.uk

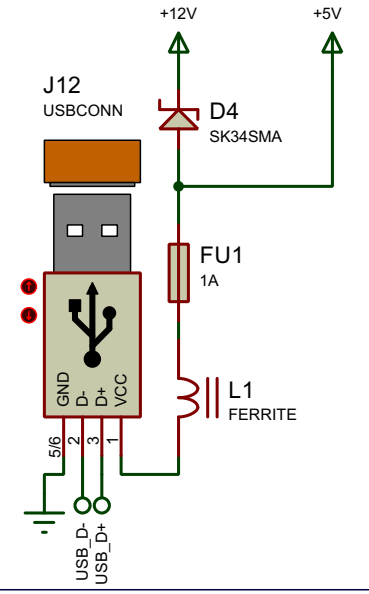
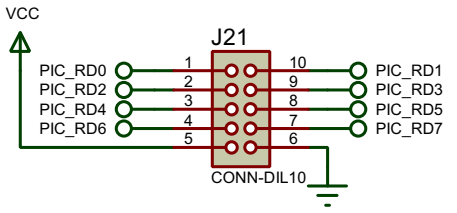
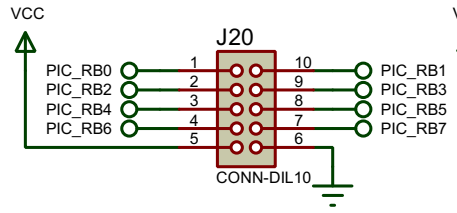
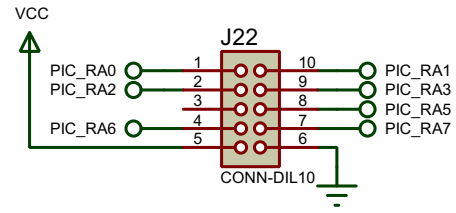
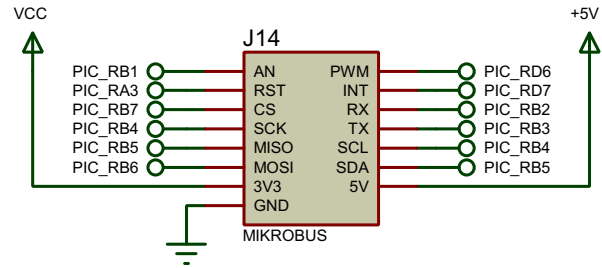
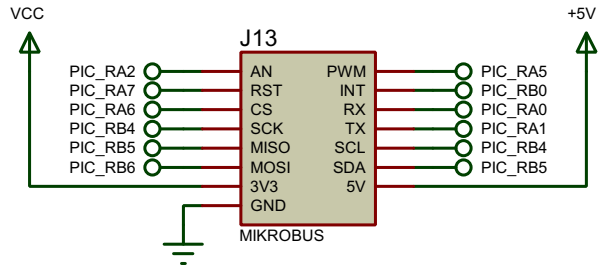

Power Supply

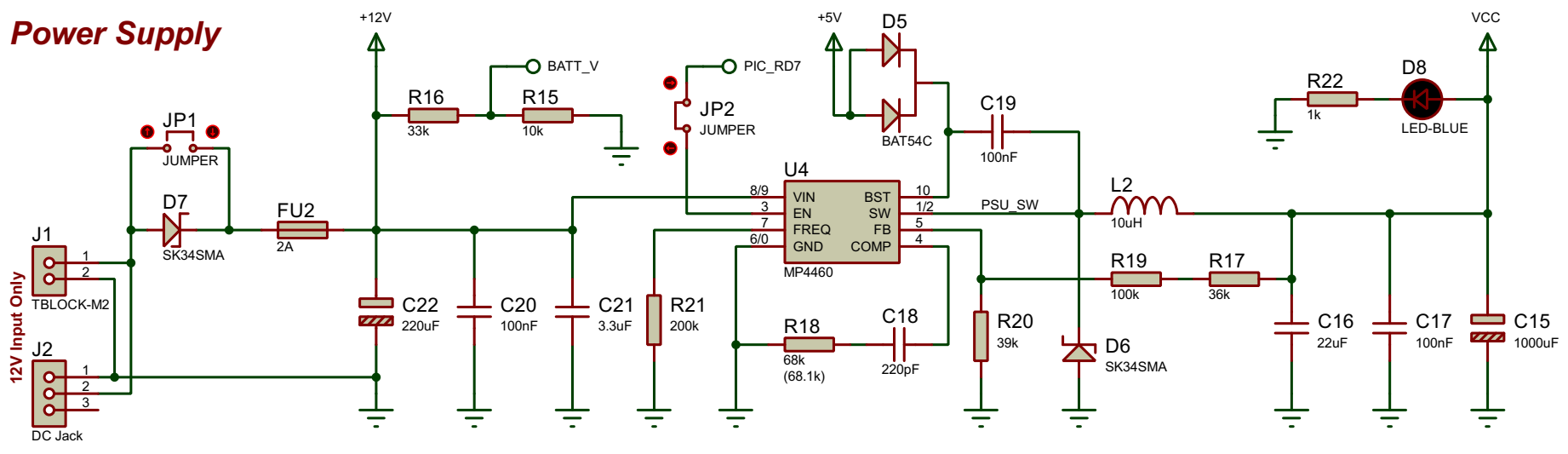

GSM/GPRS

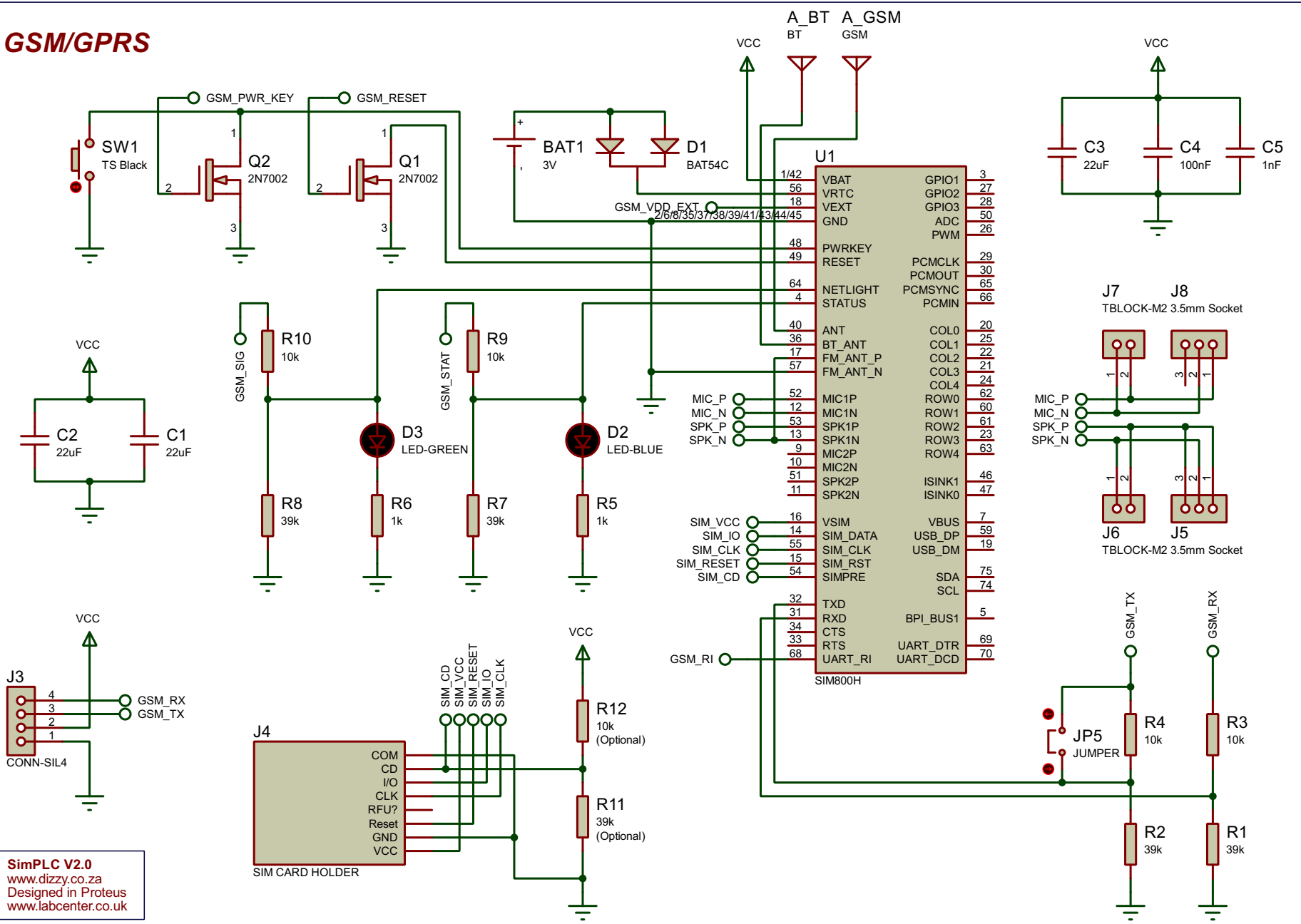

SimPLC V2.0
www.dizzy.co.za
 Designed in Proteus
www.labcenter.co.uk

Relays

SimPLC V2.0
www.dizzy.co.za
Designed in Proteus
www.labcenter.co.uk

